



GEM TRADE LABORATORY



A DIVISION OF GIA ENTERPRISES, INC.
A WHOLLY OWNED SUBSIDIARY OF THE NONPROFIT
GEMOLOGICAL INSTITUTE OF AMERICA, INC.

580 FIFTH AVENUE
NEW YORK, NY 10036-4794
212-221-5858
FAX: 212-575-3095

5355 ARMADA DRIVE
CARLSBAD, CA 92008-4699
760-603-4500
FAX: 760-603-1814

10303705

COLORED DIAMOND IDENTIFICATION AND ORIGIN REPORT

MAR 03 1998

This Report is not a guarantee, valuation or appraisal. Its contents represent the opinion of the GIA Gem Trade Laboratory at the time of grading, using examination and/or analysis. The recipient of this report may wish to consult a credentialed jeweler or gemologist about the information contained herein.

At the time of the examination, the characteristics of the diamond described herein were based upon the following as applicable: magnification (fully corrected loupe and binocular microscope), millimeter gauge, non-contact measuring device, ProportionScope, electronic carat balance, master and color comparison diamonds, additional visual color comparisons, standardized color calibration charts, ultraviolet lamps, spectroscopes, polariscope, specific gravity liquids, ultraviolet-visible and infrared spectrometers, X-ray fluorescence spectrometer, gamma-ray spectroscopy systems, beta radiation scintillation detector, radiation survey meter, X-ray luminescence equipment, and ancillary instruments as necessary.

SHAPE & CUTTING STYLE
Measurements
Weight
COLOR
Origin
Grade
Distribution

MARQUISE BRILLIANT
7.65 X 3.56 X 2.52 MM
0.44 CARAT

NATURAL
FANCY
BLUE
EVEN

COMMENTS

GIA
**COLORED
DIAMOND**
scale

Generic illustration
of GIA fancy color grade
interrelationships

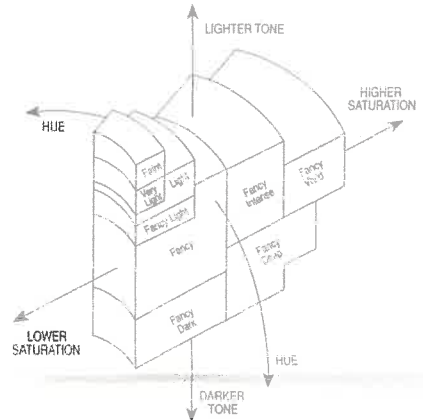

This hologram is an additional
measure of assurance of a
GIA Gem Trade Laboratory Report.



GEM TRADE LABORATORY



A DIVISION OF GIA ENTERPRISES, INC.
A WHOLLY OWNED SUBSIDIARY OF THE NONPROFIT
GEMOLOGICAL INSTITUTE OF AMERICA, INC.

580 FIFTH AVENUE
NEW YORK, NY 10036-4794
212-221-5858
FAX: 212-575-3095

5355 ARMADA DRIVE
CARLSBAD, CA 92008-4699
760-603-4500
FAX: 760-603-1814

10303703

COLORED DIAMOND IDENTIFICATION AND ORIGIN REPORT

MAR 03 1998

This Report is not a guarantee, valuation or appraisal. Its contents represent the opinion of the GIA Gem Trade Laboratory at the time of grading, testing, examination and/or analysis. The recipient of this Report may wish to consult a credentialed jeweler or gemologist about the information contained herein.

At the time of the examination, the characteristics of the diamond described herein were based upon the following as applicable: magnification (fully corrected loupe and binocular microscope), millimeter gauge, non-contact measuring device, ProportionScope, electronic carat balance, master and color comparison diamonds, additional color calibration diamonds, color calibration equipment and light sources, ultraviolet lamps, spectroscope, polariscope, specific gravity liquids, ultraviolet-visible and infrared spectrometers, X-ray fluorescence spectrometer, gamma-ray spectroscopy systems, beta radiation scintillation detector, radiation survey meter, X-ray luminescence equipment, and ancillary instruments as necessary.

SHAPE & CUTTING STYLE
Measurements
Weight
COLOR
Origin
Grade
Distribution

MARQUISE BRILLIANT
7.73 X 3.74 X 2.67 MM
0.47 CARAT

NATURAL
FANCY
BLUE
EVEN

GIA
**COLORED
DIAMOND**
SCALE

Generic illustration
of GIA fancy color grade
interrelationships.

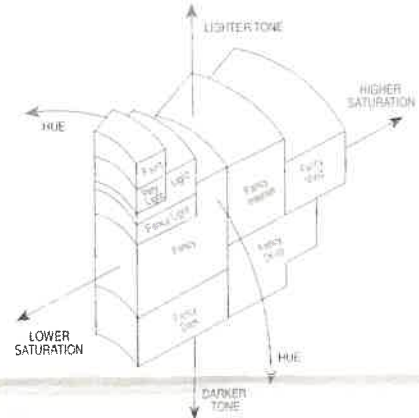

COMMENTS



This hologram is an additional
measure of assurance of a
GIA Gem Trade Laboratory Report.



GIA GEM TRADE LABORATORY

A Division of GIA Enterprises, Inc.
A Wholly Owned Subsidiary of the Nonprofit Gemological Institute of America, Inc.

10387607

580 Fifth Avenue
New York, New York 10001-4794
(212) 221-5858
FAX: (212) 575-3095

5355 Armada Drive
Carlsbad, California 92008-4099
(760) 603-4500
FAX: (760) 603-1614

JUN 24 1998

DIAMOND GRADING REPORT

THE FOLLOWING WERE, AT THE TIME OF THE EXAMINATION, THE CHARACTERISTICS OF THE DIAMOND DESCRIBED HEREIN BASED UPON 10X MAGNIFICATION (FULLY CORRECTED TRIPLET LOUPE AND BINOCULAR MICROSCOPE), DIAMONDLITE AND MASTER COLOR COMPARISON DIAMONDS, ULTRAVIOLET LAMPS, MILLIMETER GAUGE, CARAT BALANCE, PROPORTIONSCOPE AND ANCILLARY INSTRUMENTS AS NECESSARY.

RED SYMBOLS DENOTE INTERNAL CHARACTERISTICS (INCLUSIONS). GREEN SYMBOLS DENOTE EXTERNAL CHARACTERISTICS (BLEMISHES). SYMBOLS INDICATE TYPE, POSITION AND APPROXIMATE SIZE OF CHARACTERISTICS. DETAILS OF FINISH ARE NOT SHOWN. DIAGRAM MAY BE APPROXIMATE.

KEY TO SYMBOLS

SHAPE AND CUTTING STYLE MARQUISE BRILLIANT
Measurements 14.08 X 6.85 X 4.10 MM.
Weight 2.19 CARATS

PROPORTIONS ...
Depth 59.9 %
Table 62 %
Girdle THIN TO SLIGHTLY THICK, FACETED
Culet SMALL

FINISH
Polish VERY GOOD
Symmetry VERY GOOD

CLARITY GRADE ... INTERNALLY FLAWLESS

COLOR GRADE ... D

Fluorescence NONE

COMMENTS:

MINOR DETAILS OF POLISH ARE NOT SHOWN.

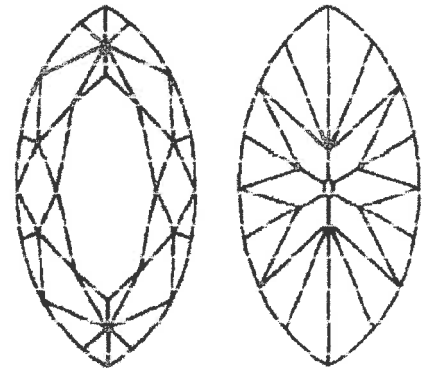

ORIGINAL

GIA GEM TRADE LABORATORY

GIA Gem Trade Laboratory

GIA CLARITY GRADING SCALE

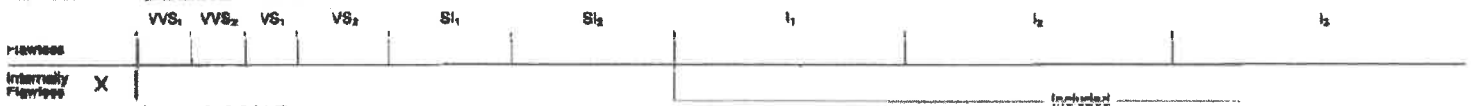

GIA COLOR GRADING SCALE

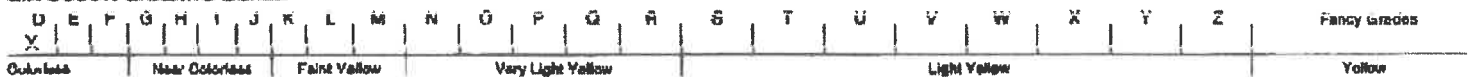

This report is not a guarantee, valuation or appraisal. The recipient of this report may wish to consult a credentialed Jeweler or Gemologist about the importance and interrelationship of cut, color, clarity and carat weight.